

# ZANUSSI

## REFRIGERATOR

---

ZT 56 RL  
ZT 56 RAL

INSTRUCTION BOOKLET

# CONTENTS

## Instructions for the user

<b>Important Safety Instructions</b>	<b>3</b>
<b>Description of the Appliance</b>	<b>4</b>
<b>Operation</b>	<b>5</b>
Before use	5
Setting the temperature	5
Fresh food refrigeration	5
Normal Operating Sounds	5
<b>Health and safety guidelines</b>	<b>6</b>
<b>Defrosting</b>	<b>7</b>
<b>Maintenance and Cleaning</b>	<b>8</b>
Internal cleaning	8
External cleaning	8
Changing the light bulb	8
When the appliance is not use	8
<b>Something not Working?</b>	<b>9</b>
<b>Service and Spare Parts</b>	<b>10</b>
<b>Customer Care Department</b>	<b>10</b>
<b>Guarantee Conditions</b>	<b>11</b>

## Instructions for the installer

<b>Technical specifications</b>	<b>12</b>
<b>Installation</b>	<b>12</b>
Positioning	12
Door Reversal	13
<b>Electrical Connection</b>	<b>14</b>



# IMPORTANT SAFETY INSTRUCTIONS

These warnings are provided in the interests of your safety. Ensure that you understand them all before installing or using this appliance. Your safety is of paramount importance. If you are unsure about any of the meanings of these warnings contact the Customer Care Department.

## Prior to Installation

- Check the appliance for transport damage. Under no circumstance should a damaged appliance be installed. In the event of damage please contact your retailer.

## Installation

- This appliance is heavy. Care should be taken when moving it.
- It is dangerous to alter the specifications or attempt to modify this product in any way.
- Ensure that the appliance does not stand on the electrical supply cable.  
**Important:** if the supply cable is damaged, it must be replaced by a special cord or assembly available from the manufacturer or your local Service Force Centre.
- Any electrical work required to install this appliance should be carried out by a qualified electrician or competent person.
- Parts which heat up should not be exposed. Whenever possible, the back of the appliance should be close to a wall, but leaving the required distance for ventilation, as stated in the installation instructions.
- The appliance should be left for 2 hours after installation before it is turned on, in order to allow the refrigerant to settle.

## Refrigerant

- During transportation and installation of the appliance, be certain that none of the components of the refrigerant circuit become damaged.
- If the refrigerant circuit should become damaged:
  - avoid open flames and sources of ignition.
  - thoroughly ventilate the room in which the appliance is situated.

## Child Safety

- Do not allow children to tamper with the controls or play with the product.
- There is a risk of suffocation! Keep packaging material away from children!

## During Use

- This appliance is designed for domestic use only, specifically for the storage of edible foodstuffs only. It is not intended for commercial or industrial use.
- Containers with flammable gases or liquids can leak at low temperatures. Do not store any containers with flammable materials, such as spray cans, fire extinguisher refill cartridges etc. in the refrigerator.

## Maintenance and Cleaning

- Before cleaning, always switch off the appliance and disconnect from the electrical supply.
- When unplugging always pull the plug from the mains socket, do not pull on the cable.

## Servicing

- This product should be serviced by an authorised engineer and only genuine spare parts should be used.
- Under no circumstances should you attempt to repair the appliance yourself. Repairs carried out by inexperienced persons may cause injury or serious malfunctioning. Contact your local Service Force Centre.

## At the end of the Appliance Life

- When disposing of your appliance use an authorised disposal site.
- Remove the plug and ensure that any locks or catches are removed, to prevent young children being trapped inside.

## **i** DESCRIPTION OF THE APPLIANCE

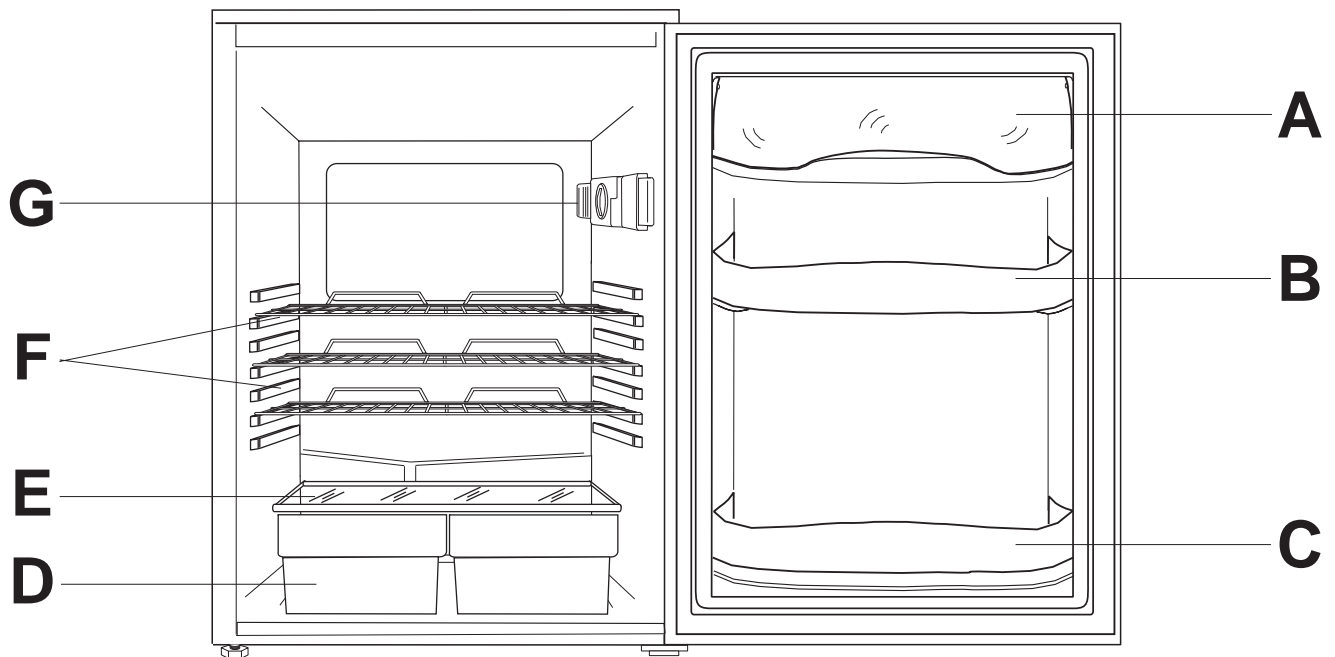

- A** - Dairy compartment
- B** - Can storage shelf with egg tray
- C** - Bottle storage shelf
- D** - Salad drawers

- E** - Glass shelf (for storing fresh meat)
- F** - Storage shelves (one with flap)
- G** - Thermostat control

# OPERATION

## Before use

Remove all securing tapes. Wash inside the appliance with lukewarm water and bicarbonate of soda (5 ml to 0.5 litre of water). Do not use soap or detergent as the smell may linger. Dry thoroughly.

## Setting the temperature

The temperature inside the refrigerator is regulated by a thermostat with 6 temperature positions and one «OFF» (O) position.

Position 1 = minimum coldness

Position 6 = maximum coldness

Turn the thermostat dial to the required position.

An intermediate position is usually the most suitable, although the temperature will be affected by:

- Room temperature
- How often the door is opened
- How much food is stored
- Position of the appliance

In determining the correct temperature control setting all these factors have to be considered and some experimentation may be necessary.

When altering the temperature setting, allow 24 hours for the temperature to stabilise before making further changes.



### Important

If the fridge is not defrosting correctly, it is possible that because a very low temperature has been selected, the motor is working continuously, which prevents the defrost cycle from operating.

To ensure correct defrosting, a lower number should be selected on the thermostat and you should notice that the motor cuts out from time to time, which is correct.

If you wish to return to a lower temperature, turn the thermostat to a higher number, however you should turn the setting lower occasionally to allow automatic defrosting.

## Fresh food refrigeration

To obtain the best performance, do not store warm food or evaporating liquids in the refrigerator; do cover or wrap the food, particularly if it has a strong flavour.

Do not cover the shelves with any protective material, such as paper, cardboard or plastic, which may obstruct the air circulation through them.

To help you use your refrigerator correctly, here are some more useful hints:

**Raw meat** (beef, pork, lamb & poultry): wrap in polythene bags and place on top of the salad drawers.

**Meat can only be stored safely in this way for one or two days at the most.**

**Fruit & vegetables:** these should be thoroughly cleaned and placed in the bottom salad drawers.

**Butter & cheese:** these should be placed in special airtight containers or wrapped in aluminium foil or polythene bags to exclude as much air as possible.

**Milk bottles:** these should have a cap and should be stored in the bottle rack on the door.

The walls of the refrigerator are equipped with runners so that shelves can be positioned as desired.

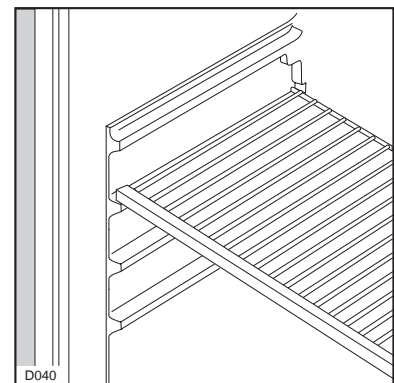

## Normal Operating Sounds

You may hear faint gurgling or bubbling sounds when the refrigerant is pumped through the coils or tubing at the rear, to the cooling plate.

When the compressor is on, the refrigerant is being pumped round, and you will hear a whirring sound or pulsating noise from the compressor.

A thermostat controls the compressor, and you will hear a faint 'click' when the thermostat cuts in and out.



# HEALTH AND SAFETY GUIDELINES

Because of consumer demand, preservatives have been removed from many pre-prepared foods. This together with the changes in shopping habits to a once-a-week shop, mean that safe handling and storage of food is even more important than ever.

**The following tips should help you to ensure that the food in your home is in as perfect condition as possible.**

- Keep the time between buying chilled food and placing it in your fridge as short as possible. Tests showed that the temperature of 1 litre of orange juice rose to 22°C in an hour between the supermarket and home. It then took 11 hours to get down to 7°C in the refrigerator.
- Keep the refrigerator door closed as much as possible.
- Do not push food together too much, try to allow air to circulate around each item.
- Cool cooked food as quickly as possible but do NOT place in the refrigerator until cool. (Leave food in a cool place in order that it can then be placed in the refrigerator as soon as possible).
- Do NOT mix raw and cooked meat, they must be in separate containers. Take care not to let the meat juices drip onto other food. If the meat does drip, remove everything and clean thoroughly.
- Do not store food uncovered.
- Remove suspect food from your refrigerator and clean the interior (see "Maintenance and Cleaning").
- Never allow spillages to dry and harden.
- Store eggs in the egg rack provided in the refrigerator door. Discard any broken or chipped eggs.
- Regularly check the refrigerator door seal to ensure that it is clean and free from debris.
- Always wash your hands with soapy water and dry them with a clean towel before handling food.
- Keep work surfaces clean and avoid cross contamination by not using the same work surface or knife, without washing them thoroughly in between.

# DEFROSTING

The refrigerator automatically defrosts every time the compressor stops. The water is discharged, via the pipe, into a tray located at the back of the appliance above the compressor, where it evaporates.



## Important

To avoid defrost water overflowing into the fridge, periodically clean the water discharge hole in the centre of the V shaped drip collector at the back of the refrigerator compartment behind the fruit and salad drawers. Use the special cleaner provided which you will find already inserted into the discharge hole.

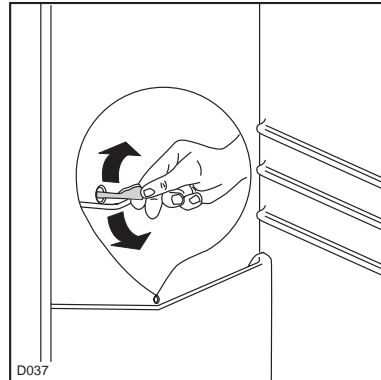

# MAINTENANCE AND CLEANING

Before any maintenance or cleaning work is carried out, DISCONNECT the appliance from the ELECTRICITY supply.

## Internal cleaning

Clean the inside and accessories with warm water and bicarbonate of soda (5ml to 0.5 litre of water). Rinse and dry thoroughly.

**NEVER USE DETERGENTS, ABRASIVE POWDERS, HIGHLY PERFUMED CLEANING PRODUCTS OR WAX POLISHES, TO CLEAN THE INTERIOR AS THESE WILL DAMAGE THE SURFACE AND LEAVE A STRONG SMELL.**

Clean the drain hole of the water trough at regular intervals and make sure that the drain hole is never obstructed, so that the defrost water may flow freely.

## External cleaning

Wash the outer cabinet with warm soapy water. Do NOT use abrasive products.

Once or twice a year dust the condenser (black grill) and the compressor at the back of the appliance, with a brush or vacuum cleaner, see the figure.

You MUST ensure that the appliance is switched OFF. An accumulation of dust will affect the performance of the appliance and cause excessive electricity consumption.

## Changing the light bulb

Should the interior light fail to work, first switch off the appliance and disconnect from the electricity supply, then replace the bulb as follows, see figure.

Unscrew the light cover and then pull it outward toward the middle of the cabinet. Unscrew the bulb and replace it with a new 15 watt bulb (available from your nearest Zanussi Service Centre).

Replace the light cover by sliding it into its original position and replacing the screw.

## When the appliance is not in use

When the appliance is not in use for long periods, disconnect from the electricity supply, empty all foods and clean the appliance, leaving the door ajar to prevent unpleasant smells.

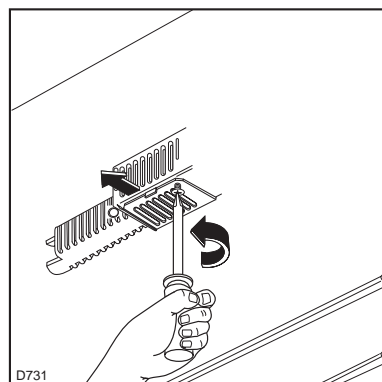
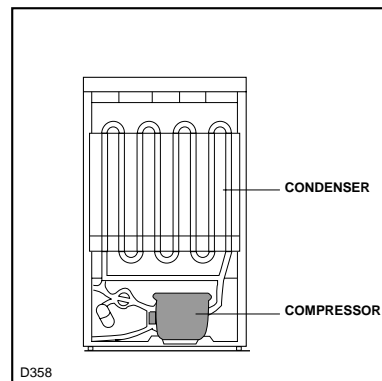



# SOMETHING NOT WORKING?

**Before** contacting your local Service Force Centre check the following points.

**IMPORTANT:** If you call out an engineer to a fault listed below, or to repair a fault caused by incorrect use or installation, a charge will be made even if the appliance is under guarantee.

<b>Symptom</b>	<b>Solution</b>
<b>No power to appliance</b>	<ul style="list-style-type: none"> <li>- Check there is power at the socket.</li> <li>- Check there is not a power cut by checking the household lights.</li> <li>- Check the fuse has not blown.</li> </ul>
<b>The light does not come on</b>	<ul style="list-style-type: none"> <li>- Ensure that the bulb is correctly fitted.</li> <li>- Replace the bulb if it has blown.</li> <li>- Check the door light switch is not jammed.</li> </ul>
<b>The temperature in the fridge is too high</b>	<ul style="list-style-type: none"> <li>- Check the ambient temperature is within the appliances operating limits of 10°C to 32°C. Relocate the appliance if necessary.</li> <li>- Check the thermostat is turned to the correct setting relative to ambient conditions.</li> </ul>
<b>The compressor runs continuously</b>	<ul style="list-style-type: none"> <li>- Adjust the thermostat to give correct temperature control. See page 5.</li> <li>- Check that the door is closed.</li> <li>- Large quantities of food have recently been placed in the cabinet/and or door is frequently opened.</li> <li>- Check that air ventilation is not obstructed.</li> </ul>
<b>Excessive frost and ice has built up</b>	<ul style="list-style-type: none"> <li>- Ensure the door is not left open.</li> <li>- Check that nothing is preventing the door from closing.</li> <li>- Is the door gasket intact and clean.</li> </ul>
<b>Noise</b>	<ul style="list-style-type: none"> <li>- Refer to normal operating sounds.</li> </ul>
<b>Water under the salad drawers</b>	<ul style="list-style-type: none"> <li>- Check the drain hole is not blocked (see "Maintenance and Cleaning").</li> </ul>

If after the above checks, there is still a fault, call your local Service Force Centre.

In-guarantee customers should ensure that the above checks have been made as the engineer will make a charge if the fault is not a mechanical or electrical breakdown.

Please note that proof of purchase is required for any in-guarantee service calls.

# SERVICE AND SPARE PARTS



In the event of your appliance requiring service, or if you wish to purchase spare parts please contact your local Zanussi Service Force Centre by telephoning:

**08705 929929**

Your call will be routed to the Service Force Centre covering your post code area. The address of your local Service Force Centre is detailed in the accompanying Customer Care Book.

Before calling out an engineer, please ensure you have read the details under the heading 'Something Not Working?'

When you contact the Service Centre you will need to give the following details.

1. Your name, address and post code
2. Your telephone number
3. Clear and concise details of the fault
4. The model serial no. of the appliance (found on the rating plate)
5. The purchase date

# CUSTOMER CARE DEPARTMENT

For general enquiries concerning your Zanussi appliance or for further information on Zanussi products, you are invited to contact our Customer Care Department by letter or telephone as follows:

Customer Care Department  
Zanussi  
55-77 High Street  
Slough  
Berkshire  
SL1 1DZ

Tel: 08705 727727

# GUARANTEE CONDITIONS

## Standard guarantee conditions

We, Zanussi Limited, undertake that if within 12 months of the date of purchase this Zanussi appliance or any part thereof is proved to be defective by reason only of faulty workmanship or materials, we will, at our option repair or replace the same FREE OF CHARGE for labour, materials or carriage on condition that:

- The appliance has been correctly installed and used only on the electricity supply stated on the rating plate.
- The appliance has been used for normal domestic purposes only, and in accordance with the manufacturer's instructions.
- The appliance has not been serviced, maintained repaired, taken apart or tampered with by any person not authorised by us.
- All service work under this guarantee must be undertaken by a Zanussi Service Force Centre.
- Any appliance or defective part replaced shall become the Company's property.
- This guarantee is in addition to your statutory and other legal rights.

Home visits are made between **8.30am** and **5.30pm** Monday to Friday. Visits may be available outside these hours in which case a **premium** will be charged.

## Exclusions

### This guarantee does not cover:

- Damage or calls resulting from transportation, improper use or neglect, the replacement of any light bulbs or removable parts of glass or plastic.
- Costs incurred for calls to put right an appliance which is improperly installed or calls to appliances outside the United Kingdom.
- Appliances found to be in use within a commercial environment, plus those which are subject to rental agreements.
- Products of Zanussi manufacture which are not marketed by Zanussi Limited.

## European Guarantee

If you should move to another country within Europe then your guarantee moves with you to your new home subject to the following qualifications:

- The guarantee starts from the date you first purchased your product.
- The guarantee is for the same period and to the same extent for labour and parts as exists in the new country of use for this brand or range of products.
- This guarantee relates to you and cannot be transferred to another user.
- Your new home is within European Community (EC) or European Free Trade Area.
- The product is installed and used in accordance with our instructions and is only used domestically, i.e. a normal household.
- The product is installed taking into account regulations in your new country.

Before you move please contact your nearest Customer Care centre, listed below, to give them details of your new home. They will then ensure that the local Service Organisation is aware of your move and able to look after you and your appliance.

France	Senlis	+33 (0) 44 62 29 99
Germany	Nuremberg	+49 (0) 911 323 2600
Italy	Pordenone	+39 (0) 1678 47053
Sweden	Stockholm	+46 (0) 8 738 79 50
UK	Slough	+44 (0) 1753 219897

# TECHNICAL SPECIFICATIONS

DIMENSIONS	Height	85	cm
	Width	54,5	cm
	Depth	60	cm

POWER SUPPLY VOLTAGE AND FREQUENCY	220-240 V / 50 Hz
TOTAL POWER ABSORBED	110 W
AVERAGE DAILY UNITS ELECTRICITY(*)	0,69 kWh

GROSS CAPACITY 160 l

NET CAPACITY 154 l

(\*)This figure is based on standard test results in accordance with European Standard EN153. Actual consumption will depend on how the appliance is used and where it is located.

# INSTALLATION

## Positioning

For this appliance to work efficiently, it must not be located where the temperatures will fall below 16°C (61°F) or rise above 32°C (90°F), e.g. conservatories.

For correct operation this appliance must be located in a dry atmosphere, away from heat sources, e.g. cookers, radiators, boilers and direct sunlight.

You should also ensure that air can circulate freely around the back and the top of the cabinet. There should be a minimum distance between the top of the cabinet and any overhanging kitchen furniture as shown in the figure.

Do not obstruct the space underneath. The back of the cabinet may be placed close to the wall but must not touch it. DO NOT install in places with restricted ventilation.

Adjust the level of the appliance by screwing out the adjustable foot, or feet, at the bottom of the cabinet using your fingers.

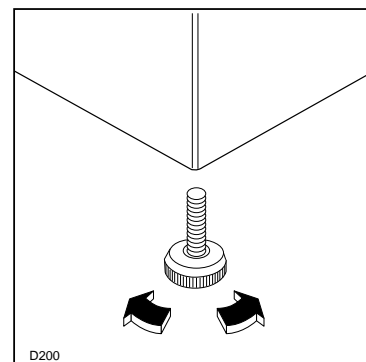
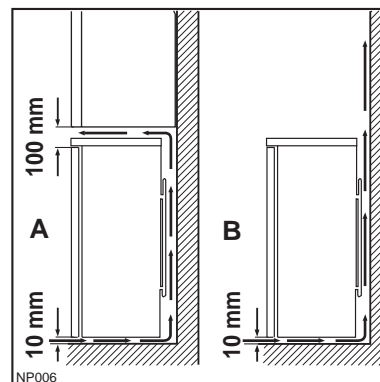

## Door Reversal

Before carrying out the operations described below, pull out the mains plug from the wall socket.

To carry out this reversal go through the following steps:

1. Gently lay the appliance on its back with the top held away from the floor by 5-8 cm (2-3 inches) of packing.
2. Remove the bottom door hinge (5).
3. Remove the door (4) by opening it and pulling it gently downwards to remove it from the top hinge pin (2).
4. Unscrew the top hinge pin (2) from the top hinge (1) and replace it in the opposite hole on the left hand side.
5. Unscrew the foot at the base (6) of the appliance and refit it on the opposite side.
6. Refit the door and the bottom hinge to the left hand side.

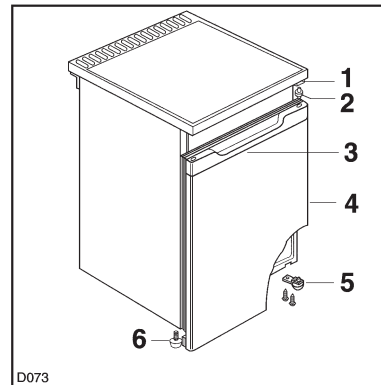

**When positioning the bottom hinge blade on the reverse side, the securing screws will require a degree of exertion when fitting. It is therefore advisable to lubricate the screw tips before starting this operation.**



### Important

After completion of the door reversal operation, verify that the door gasket is sealing onto the cabinet.

# ELECTRICAL CONNECTION



## WARNING:

**THIS APPLIANCE MUST BE EARTHED.**  
The manufacturer declines any liability should this safety measure not be observed.

If the plug that is fitted to your appliance is not suitable for your socket outlet, it must be cut off and the appropriate plug fitted.

Remove the fuse from the cut off plug.

The cut off plug should then be disposed of to prevent the hazard of shocks in case it should be plugged into a 13amp socket in another part of your home.



## Important

The wires in the mains lead are coloured in accordance with the following code:

<b>Green and Yellow</b>	- <b>Earth</b>
<b>Blue</b>	- <b>Neutral</b>
<b>Brown</b>	- <b>Live</b>

If you fit your own plug, the colours of the wires in the mains lead of your appliance, may not correspond with the markings identifying the terminals in your plug, proceed as follows:

Connect the Green and the Yellow (earth) wire to the terminal in the plug which is marked with the letter «E» or the earth symbol  $\oplus$ , or coloured green and yellow.

Connect the blue (neutral) wire to the terminal in the plug which is marked with the letter «N» or coloured black.

Connect the brown (live) wire to the terminal in the plug which is marked with the letter «L» or coloured red.

The plug moulded onto the lead incorporates a fuse. For replacement, use a 13amp BS1362 fuse. Only ASTA or BSI approved fuses should be used.

The plug must not be used if the fuse cover/carrier is lost. The cover/carrier is indicated by the coloured insert at the base of the plug.

A replacement cover/carrier must be obtained from your local Zanussi Service Force Centre whose address is listed in the Customer Care Booklet which accompanies your instruction manual.

This appliance complies with the E.E.C. Directive No. 87/308 of 2.6.87 relative to radio interference suppression.



This appliance complies with the following E.E.C. Directive:

- **73/23 EEC** of 19.2.73 (Low Voltage Directive) and subsequent amendments.
- **89/336 EEC** of 3.5.89 (Electromagnetic Compatibility Directive) and subsequent amendments.

**Please ensure that when the appliance is installed it is easily accessible for the engineer in the event of breakdown.**

